

# ALARM DISPLAY UNIT LLD 10/15

For electricians

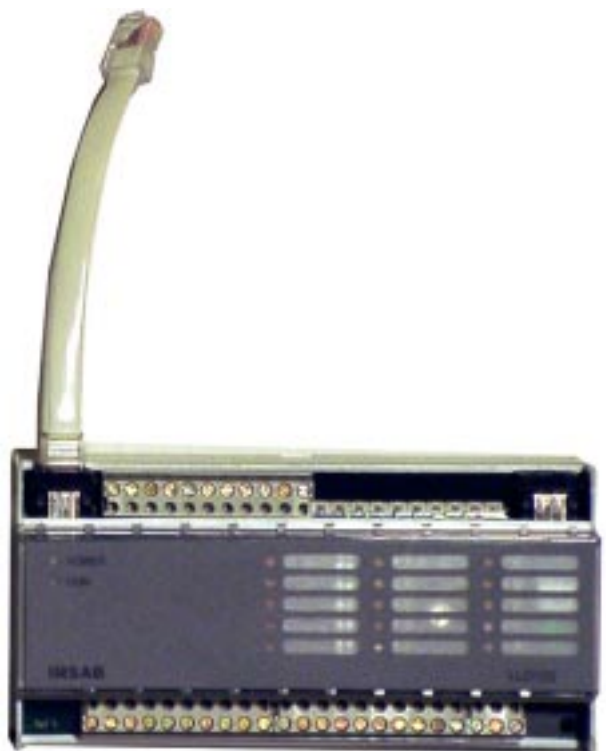

- Alarm unit for "surface-mounting distribution boards and enclosures"
- 10 selectable error switch inputs (NO/NC)
- Can be complemented with up to 6 slave panels with 15 points to a total of 100 alarm points
- 3 selectable alarm groups (A-B-C alarm)
- Flashing light and memory for each point
- Independent time-delay 50 ms - 70 sec
- Zero voltage check
- Option available for transfer of information to a computer

## ADVANTAGES AND OPERATION

On the panel, the sensors indicator flashes when the pre-set time delay has elapsed. At the same time the output group(s) attached to the alarm point are activated. Further error messages are not blocked by earlier signals. Error messages are acknowledged by pressing the "RESET" button. The output terminal are then reset, at the same time as the alarm indicator changes to a constant light. When the fault has been fixed and the sensors switch has return to its normal state, then the alarm indicator goes out. If a fault should fix itself and the switch reset itself before acknowledgement has occurred, then the panel recalls the fault. The flashing light and output contact are activated until acknowledgement has occurred. The LLD 10 unit is thus equipped with a memory function and is always ready for a new alarm.

Pressing the TEST button makes a standard test of operation.

**Lamp test** can be done with a push at the button TEST.

**Functions test** can be done with a push at the button TEST + PROG button at same time, which simulate fault at the panel.

The green operation indication's diode lights up when voltage is following through the panel.

## SECURITY

The LLD 10 unit is constructed for surveillance work even under extreme conditions. Like all IMSAB alarm products it is equipped with multiple protection against accidental connection to voltages, interference etc. Alternating voltage can be fed directly into the panel without the requirement for stabilisation. It also has a built in zero voltage control, which means that the output relay for each alarm group is normally junctured. In case of alarm or voltage falloff the output relays break.

CE-tested and approved according to: EN 50 082-2; IEC 801-2:1991; ENV 50 140; ENV 50 141; IEC 801-4

## INSTALLATION

The LLD 10 unit is designed for mounting on a DIN-rail in a normal enclosure and its compact form make it easy to fit in any enclose. There is a master and slave version. If more than 10 alarm points are required in the construction, then it can be complemented with slaves with 15 points. Connection is made to the unit by an easily accessible screw terminal block, which can be fitted with a corresponding terminal strip. This connection method means that no cable need to be loosened after installation. In a few moments it is easy to part the cable from the panel.

## PROGRAMMING

The LLD10M unit can be adjusted in a number of ways. Here are a number of the key features of the LLD10M unit:

- Alarm inputs work with normally open (NO) or normally closed (NC) contacts. Individually selectable for each input.
- For each alarm input a separate time delay of 0 - 75 seconds can be selected.
- Each alarm input can be connected to none or several relay outputs. The LLD10M unit is delivered with a standard setting of alarm inputs and relay outputs. Standard setting:
  - All alarm inputs are set to work with normally open (NO) alarm contacts.
  - All alarm inputs are set at 0 seconds time delay.
  - All alarm inputs are connected to the A-alarm relay output.

### Programming construction

Construction of the programming method is such that:

- 1 Firstly is selected which unit in the system where alarm inputs exist that is to be programmed or changed. (The number of units depends on how large the system is, namely between one to seven units).
- 2- Once the unit is selected, next is selected which of the five (5) rows of inputs the input(s) are to be found.
- 3- Once the actual row is selected, then the individual alarm input that is to be programmed or changed is selected. (Here there are five (5) to select from).
- 4- At the individual input level there are three (3) different setting to select:
  - Firstly is selected if the input should work as a normally closed (NC) or normally open (NO) alarm contact.
  - Next is selected, by adding time intervals, which time delay the



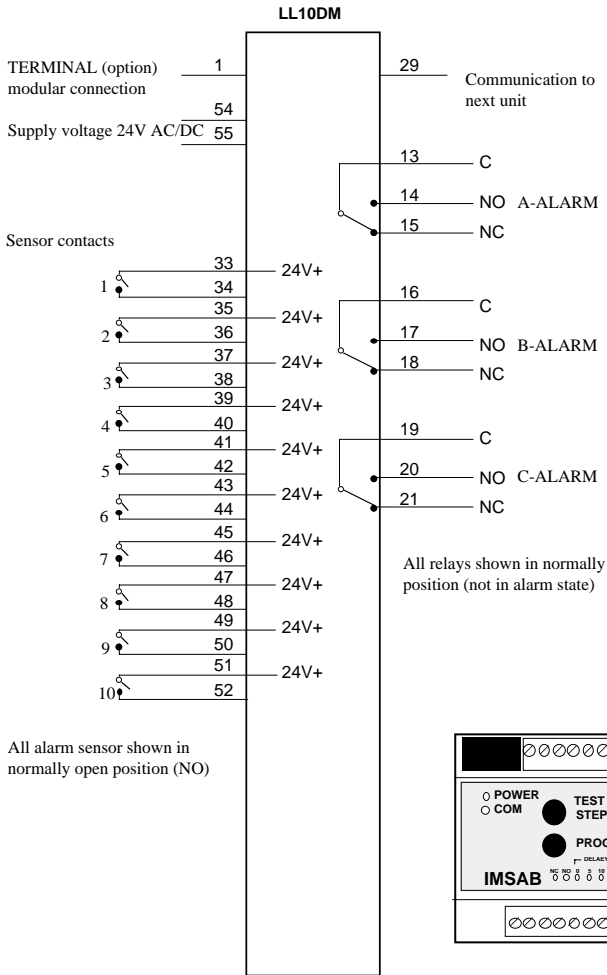

input should have from the physical alarm until the LLD10M system informs the alarm categories that the alarm has occurred. Finally is selected which alarm categories (A-B-C alarms) that should be activated with an alarm at that alarm input. Between 0-3 can be selected.

## SPECIFICATIONS

Power supply: 24V AC/DC  $\pm$  20%; 80-200mA  
 Outputs: Isolated volt-free contact per alarm group (A-B-C alarm) max 24VDC 1A/ 48VAC 1A res. last.  
 Time delay: Individually selectable delay 0.05-75 sec/channel.  
 Front: Grey plastic with pockets for the alarm points  
 Dimensions: 75x150x60 mm (hxbxd)  
 Ambient temperature: +5°C to +40°C  
 Humidity: 10- 90% Relative Humidity, not condensed  
 Legends: Space for 2-3 5-point legends  
 Indicator: Red light diodes = error signals  
 Enclose class: IP20

## ORDERING INSTRUCTIONS

Master LLD10M  
 Slave LLD15S  
 Option: Interface board for communication with a controlling supervising computer (RS232).

